

# 10. CONTROLLING GROUNDLINE AND WATERLINE ROT

The most vigorous rotting on a structure often occurs where post, poles and piles enter the ground. From ground level to about 20 cm depth is a zone with abundant moisture present for a large proportion of the year. There is also abundant plant nutrients present, and fungi, like other forms of plant life, grow faster where nutrients, especially nitrogen, are abundant. The more fertile the soil the faster the groundline rot. Timber in stockyards, sale yards and gardens is particularly vulnerable. Groundline conditions are particularly favourable to soft rot fungi, which require higher concentrations of CN than are needed to control brown rot and white rot.

According to Swedish research one advantage of using creosote pressure treatment is that, over the lifetime of a utility pole, the creosote, gradually migrates down the pole. When it gets to where it is needed most - the groundline - it is halted by the increased moisture content. Whether this is true of brush-on/spray-on treatments is unknown. Piles driven into shingle riverbeds, waterways and tidal water present special but not insoluble problems.

## 10.1 GROUNDLINE BANDAGING

The principle of groundline protection is to put a thick layer of fungicide in contact with the timber most at risk of attack, and then to keep it there by bandaging with plastic sheeting. The bandage also serves to prevent the fungicide contaminating the soil, and helps to limit the amount of moisture, especially nutrient-rich moisture, entering the timber. Further down in the soil there is very little rot, because there is less nutrient and less oxygen (fungi, lacking chlorophyll, are dependent on atmospheric oxygen), and often because conditions are too waterlogged for fungi.

Groundline pole bandaging is a widely used technique for extending the life of utility poles in New Zealand. [Fig. 19] Soil is removed from around the pole to a depth of about 60 cm, and the pole is cleaned without removing rotten wood. A kilogram or more of Polegel is spread on a sheet of shrinkwrap plastic of size appropriate to the pole. The sleeve is then wrapped around the pole, and the vertical overlap sealed with adhesive tape. A bead of mastic at top and bottom of the sleeve provides a seal with the pole. The entire sleeve is then heated with a gas flame. This softens the mastic and shrinks the bandage tightly against the pole.

In an alternative design three plastic grease nipples are incorporated in the bandage to allow the preservative to be injected after the bandage has been sealed onto the pole. The nipples also allow recharging of the bandage after about 15 years. Preservative may migrate as much as a metre up and down the pole from the bandage.

The technique is eminently adapted to historic structures with large numbers of

piles of more or less uniform size. In such cases it is best done by trained and experienced contractors, and will cost about \$250 per pole, plus the costs of getting the team and its equipment to and from the site.

For some historic structures commercial bandaging will be far too expensive. A small number of piles will not justify the cost of getting the team in place. It is quite feasible, after some trial-and-error wastage of time and material, for DOC staff to do shrinkwrap bandaging. Materials cost about \$100 per bandage.

In other cases the shrinkwrap technique may not be suitable, such as when piles of irregular size and shape in widely varying condition and situation have to be dealt with. The technique is not suited to timbers sitting on hard-rock substrates (for example the rafters in kauri driving dams, see Appendix2).

For such structures it might be worth reviving the more primitive bandaging technique used before shrinkwrap became available. It requires no special equipment or training. Each pile is dug out as before, and cleaned. As much Polegel as possible is smeared onto the pole, which is then bandaged with any thick absorbent material to hand - an old blanket torn into strips would do fine. The absorbent bandage increases the amount of Polegel held in contact with

the pile, and evens out irregularities in the shape of the pile. More Polegel is smeared on. Everything is then spirally wrapped with at least one thickness of 100 mm wide plastic tape, and fastened. This in turn could be spirally wrapped with at least one thickness of Densotape, which binds the whole bandage together, acts as a cushion against impact damage, and gives a low-visibility surface. The Densotape should be smoothed out to make it as impermeable as possible, either to Polegel leaking out, or soil water leaking in. The soil is then carefully replaced around the pole.

The bandaging should extend about 10 cm above ground level. If there are only one or two piles needing groundline treatment then it is not worth buying a pail of Polegel for this purpose alone. CNE is also reasonably effective for groundline protection and is recommended for this purpose by manufacturer Koppers-Arch Wood Protection. The process is the same as for Polegel. Koppers-Arch Wood Protection recommend chipping away any rotten wood with a small hatchet before applying CNE. Thickened boron paste and 'Blue 7' (a diffusing preservative containing fluorine, developed by CSIRO) is also usable.

Not all timbers entering the ground will necessarily need groundline protection. Piles driven into shingle riverbeds may be completely free from groundline rot. Piles in

Fig. 19: Polegel bandage on powerpole, Kopu-Coroglen 10,000 kv line. Note vegetation growing in immediate vicinity, unharmed by Polegel.



waterlogged, clay-rich soil may be experiencing near-anaerobic conditions and have less rot at the groundline than they have above the ground.

One low-technology way of slowing down groundline rot, used extensively for utility poles in Scandinavia, is to excavate to 50 cm depth around the pole, then back-fill with clean coarse gravel. This is reported to have stopped soft rot, which was otherwise eating into poles at the rate of 2 mm per year.

## 10.2 PILES IN RIVERBEDS, WATERWAYS AND SEAWATER

Piles in high-energy shingle riverbeds may suffer from abrasion, in which case they can be protected with neoprene or butynol wrapping, held on with metal bands or wire.

Piles in slow-moving water often decay at and below the waterline through a variety of mechanisms. Rising and falling water levels create ideal conditions for mechanical weathering and fungal action. Constant immersion in moving water leads to natural preservatives ('extractives') being leached out and allows bacteria, both aerobic and anaerobic, to thrive. There are special forms of pole-bandaging, usable underwater, to deal with such situations.

The life expectancy and bearing strength of badly-rotted piles in waterways and lakes can be increased by pouring a concrete cast around the submerged part of the pile. A geotextile 'sock' is placed around the pile, and the sock is then filled with a concrete grout which will set solid underwater. Besides giving strength the concrete creates conditions unfavourable to further rot. Concrete is alkaline, and most rotting micro-organisms prefer acid conditions. The concrete prevents leaching of extractives and creates stagnant conditions in which only anaerobic bacteria will continue to function. Anaerobic decay is generally much slower than aerobic decay.

Piles in seawater can be protected from marine borers by wrapping with heavy polythene or PVC membrane. This is a recognised technique used, for example, on the Marsden Point oil refinery wharf. There are special fastening systems available to keep the plastic taut. Tautness is the important thing. Marine borers, even those that bore into rock, will not bore through plastic, but some of them can slip under slack edges. There are commercial divers skilled in pile wrapping. It looks rather ugly to start with, but generally becomes covered with intertidal growth later.

Marine piles can also be wrapped with a special marine-grade biocide-impregnated petrolatum tape ('Densotape') which can be applied underwater. This has the advantage of being 'do-able' by unskilled workers, and the end result is much less visible than the plastic membranes.

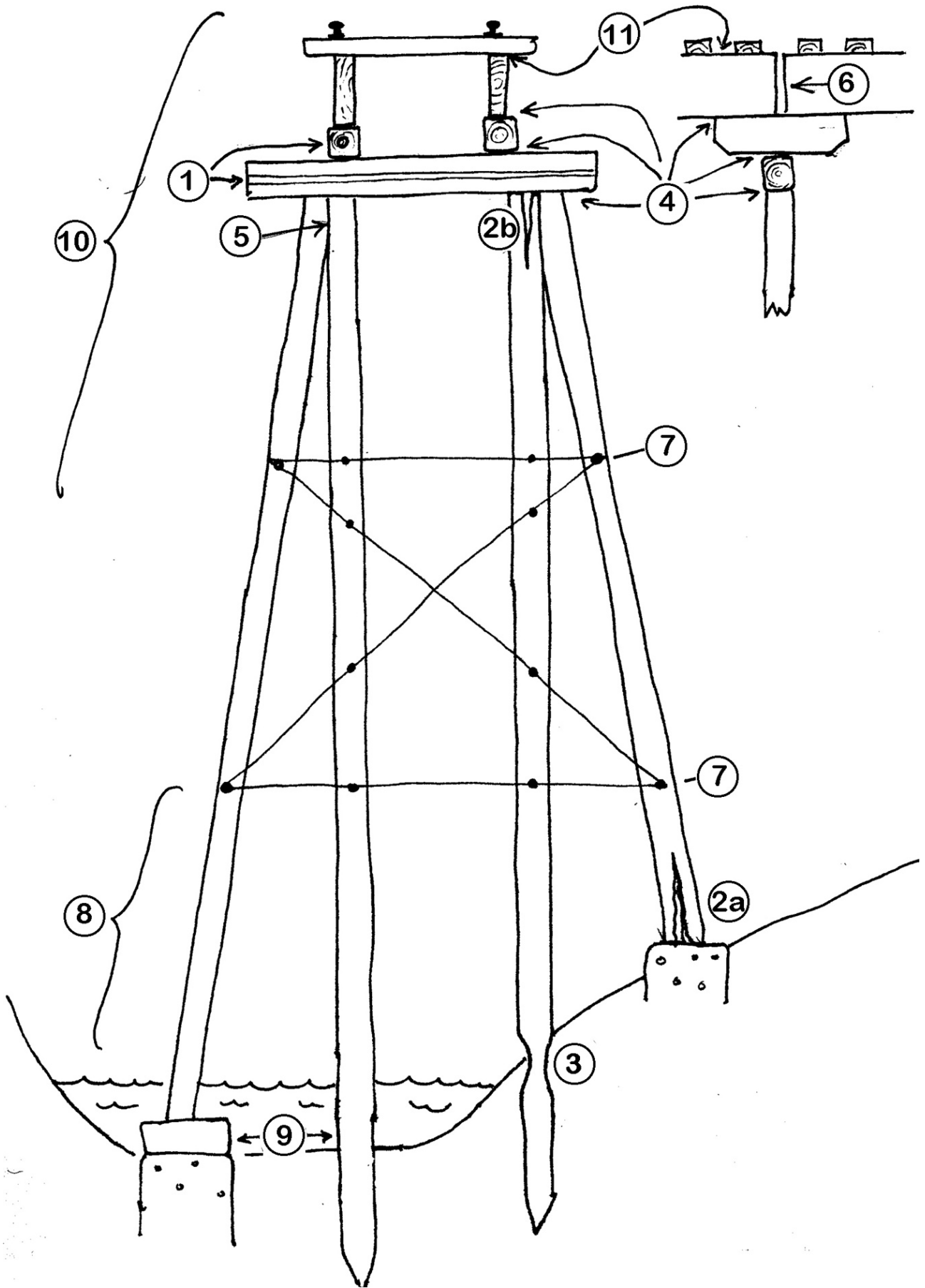

Fig. 20: Key to this image on following page.

Fig. 20: Stylised bridge trestle

On this trestle the following rot/weathering environments may prevail:

1. **Pipe rot.** This is very common in durable eucalypt, but is often of little consequence. Vertical pipe rot is often self-draining, but water may accumulate in horizontal pipe rot. It is not a sign of imminent collapse, and indeed may have been present before the tree was cut down, with little enlargement since. Pipe rot can either be ignored or treated with foam as described in section 9.2. Ideally the foam should penetrate all the way, in which case very long nozzles will be needed.
2. **Butt-end internal rot.** Durable eucalypts in particular often have bad internal rot [2a] at the butt ends. Often this rot was present in the tree before it was cut down. Note that piles were generally driven head down, so that butt end rot can be expected at what are now the upper ends [2b]. Studs were generally erected with butt-end down, in which position it is less troublesome and more easily treated. In all cases the techniques of section 9 are appropriate.
3. **Groundline rot.** See section 10.
4. **Horizontal joints.** Water tends to linger in horizontal joints, especially lap joints (grain parallel to the joint), and rot is often worse here than anywhere else on a structure. See section 11.1.
5. **Vertical side-grain joints.** These are usually self-draining and not a problem. Simply lay an extra thick bead of Polegel along the top of the joint and hope that it creeps in to where it is needed.
6. **Vertical butt joints.** Where timbers are joined end to end. These are subject to endgrain rot which is difficult to get at. Scarf joints can be worse, combining the problems of both lap and butt joints. See section 11.3.
7. **Bolt holes etc.,** do not seem to promote rot as much as one might imagine. Often expansion of the bolt from corrosion is more of a problem. Such expansion can easily split open the wood through which the bolt passes. See section 11.4.
8. **Permanently damp timbers.** The lower parts of a structure located in the bottom of a deep gorge under heavy forest canopy in a high rainfall part of the country may be more or less permanently damp and untreatable with CNE. See section 11.5.
9. **Permanently wet timbers.** For instance, the sill timbers of a kauri dam, are often surprisingly sound. Fungi require oxygen just like any other plant life, and fungal rot will not proceed in totally saturated timber. Pile timbers are generally quite sound below the groundline, for similar reasons (plus the fact that best quality timber was generally chosen for piles). There may be bacterial rot present, but this is much slower. Treatment of permanently wet timbers is not possible, it is usually not needed, and it is recommended that such timbers be left alone. In some situations they can be bandaged [section 10.2]. If there is unsound timber important to the overall integrity of the structure it may eventually have to be replaced (perhaps with H5 treated radiata pine).
10. **Timbers exposed to sun, wind & rain.** Timbers which are not shaded by vegetation, especially in low rainfall, low humidity, high sunshine regions, may be deteriorating from weathering more than from fungal rot. Alternate wetting and drying causes expansion and contraction and eventual breakdown of timber structure. The ultraviolet component of sunlight breaks down the lignin 'glue' which holds the cellulose fibres together. Such timbers will still benefit from the standard surface rot treatment, followed by a water repellent treatment. See section 12.3.
11. **'Gutter rot'.** See section 11.2. The choice of preservative chemicals for all these situations is summarised in fig. 26.