

iv) Alberta fish weirs

The fish weirs used by Alberta Transportation are weir baffles with a partial slot (Figure 16). The best designs from Rajaratnam et al. (1990) produced pool depths and barrier velocities comparable to weir and slotted weir baffles.

v) Wall baffles

Wall baffles are solid baffles placed up the sides of the culvert rather than across the bottom, and they are staggered from one side to the other (Figure 17). As far as we know, these have not been installed or tested in New Zealand, but it is likely that they would hinder passage of climbing species. Therefore, wall baffles should not be installed in New Zealand unless modelling or trials can demonstrate that they can produce a zone along the culvert wall with velocities below 0.3 m s^{-1} .

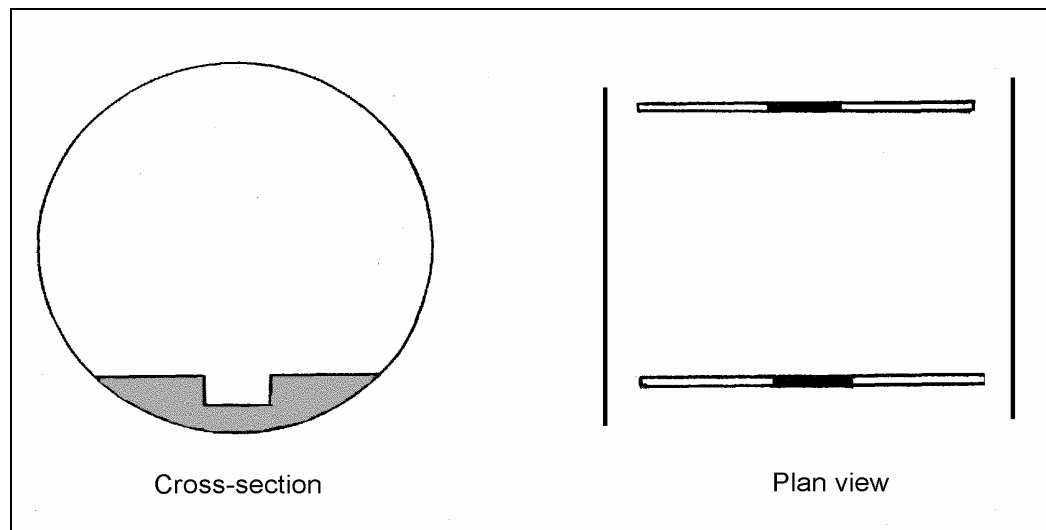

Figure 16. Alberta fish weirs. Note partial slot compared to full slot of slotted weirs. For the best designs from Rajaratnam et al. (1990); central height of the baffle = $0.14D$, and height to the top of the slot = $0.06D$, at spacings of $0.6D$ and $1.2D$, slot width = $0.22D$ (where D = culvert diameter). As with the weir baffles the edges need to be rounded to allow passage of indigenous New Zealand fish species.

vi) Spoiler baffles

Spoiler baffles are sets of blocks installed on the culvert invert (Plate 8). The best designs comprise alternating sets of four and three block-like baffles (Figure 18). They are effective at decreasing barrier velocities and increasing pool depths, but are more expensive to install in existing culverts than simpler systems (Rajaratnam et al. 1991).

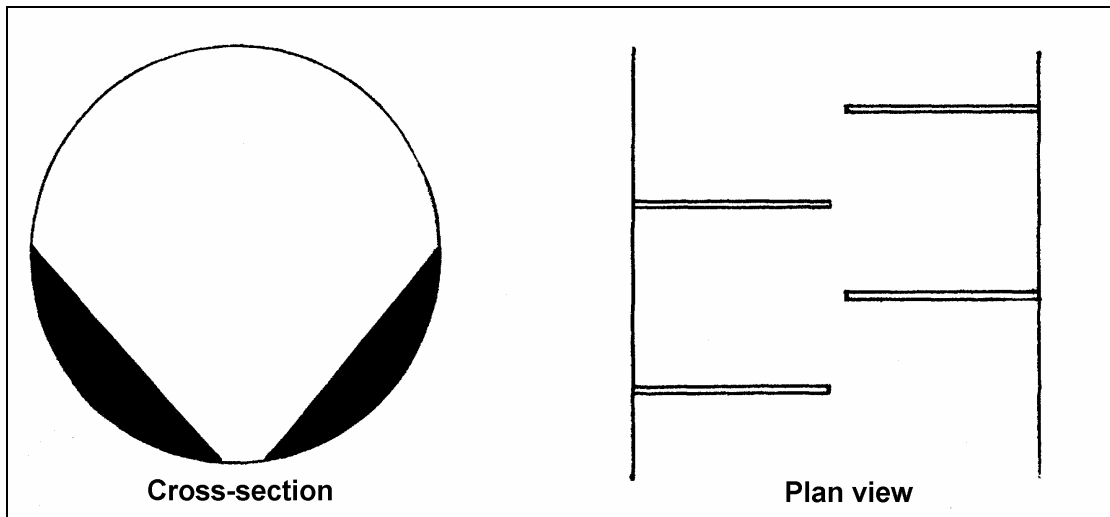

Figure 17. *Wall baffles. Installed on an angle up the sides of the culvert rather than on the bottom.*



Plate 8. *Tanalised pine spoilers installed on the invert of a new concrete culvert. Once water is restored to this culvert it will flow from right to left.*

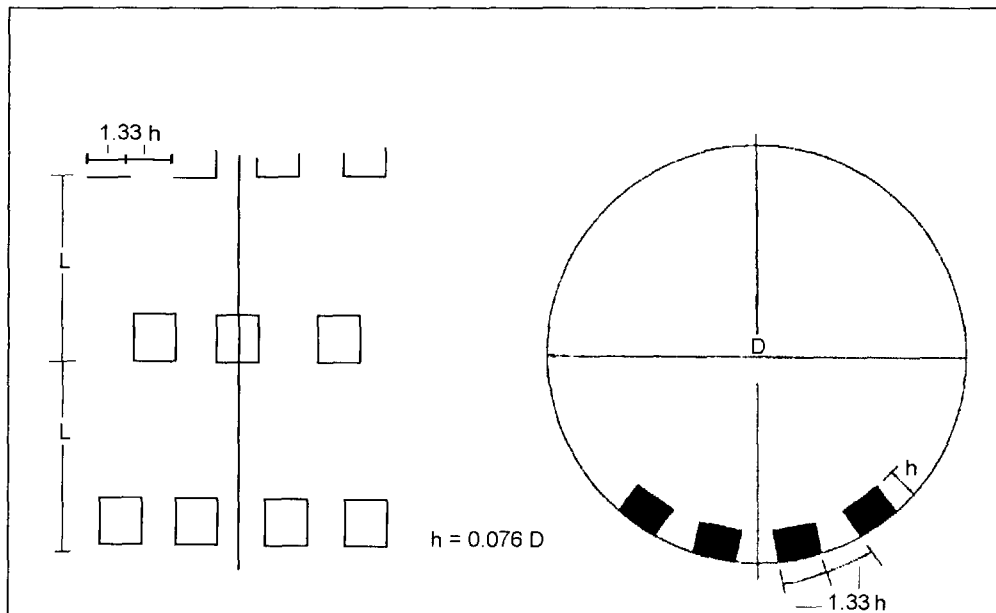

Figure 18. *Plan view (left) and cross-section (right) of spoiler baffles with alternating sets of four and three baffles. For the best designs from Rajaratnam et al. (1991); $h = 0.09D$ or $0.15D$ at a spacing of $0.53D$ (where $D =$ culvert diameter).*

The original design had the spoilers flat at the leading edge and rounded at the downstream end, but Rajaratnam et al. (1991) considered this was not the best design for energy dissipation. Our flume studies have indicated that a useful reduction of velocities can be obtained by placing the rounded end up stream. This orientation potentially reduces the probability of debris accumulating (and provides resting areas for small, New Zealand, freshwater fish species). The most useful feature of the spoilers for indigenous species is the maintenance of free pathways along the culvert floor and the presence of resting areas at both low and medium flows. Replacing the spoilers with rocks may be possible but has not been tested in New Zealand.

vii) Alberta fish baffles

Also used by Alberta Transportation, the fish baffles consist of block-like baffles arranged in a zig-zag pattern along the length of the culvert (Figure 19). Rajaratnam et al. (1990) found this system to be less effective than slotted weir baffles, weir baffles and Alberta fish weirs, because the resulting depths were smaller and resting areas may be lacking. However, trials using indigenous New Zealand fish species indicated that Alberta fish baffles and spoiler baffles were better than weirs, as they provided uninterrupted passage along the floor and edges of the culvert. Replacing the square concrete blocks depicted in the original design with rocks is possible.

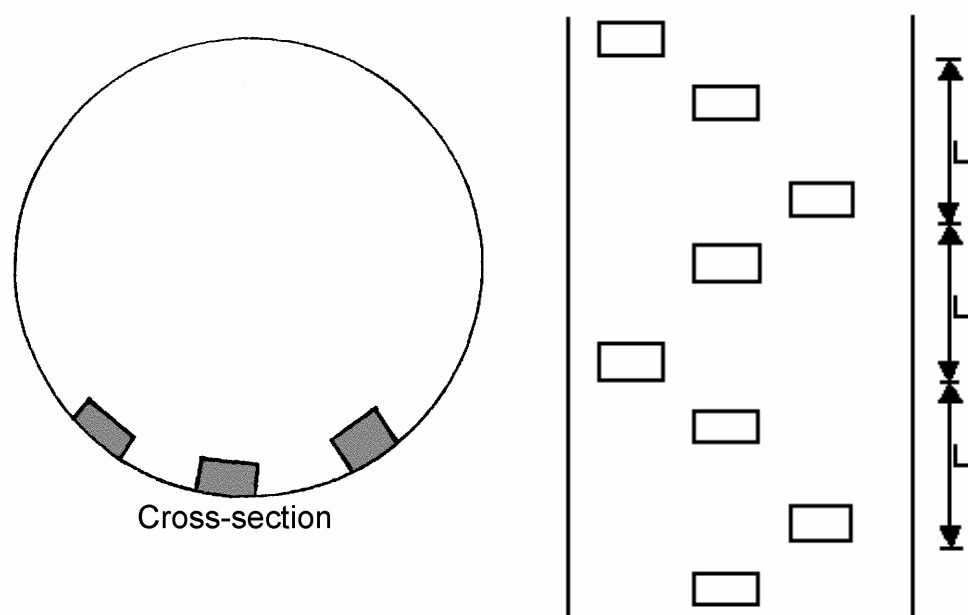

Figure 19. *Plan view (right) and cross-section of Alberta fish baffles. Note zigzag arrangement compared to spoiler baffles. In the study undertaken by Rajaratnam et al. (1990) the average baffle dimensions were: width = $0.13D$, height = $0.07D$, thickness = $0.07D$; and L/D = for the series of 3 trials made were: 1.43, 0.72 and 0.47 (where D = culvert diameter).*

9.2.2 Baffles and New Zealand species

Bates (1992) commented that none of the existing designs (weir, notch, wall and offset) were developed with juveniles (salmonids) in mind, and that they may actually block passage because of turbulence. He suggested that it is better to install baffles on one wall only, to maintain undisturbed boundary layers and conditions on the other side. This advice may be useful for New Zealand species. Relevant also is his view that baffles alternating from one side of the culvert to the other not only eliminate still (resting) areas, but also cause fish to cross backwards and forwards; this makes successful passage less likely.

Laboratory trials using inanga and smelt indicated that the modified spoiler baffles of Rajaratnam et al. (1991) were more successful than slotted weirs at easing passage in smooth culverts (Figure 9). Furthermore, this design has the advantage of ensuring that accumulation of debris within the barrel does not occur. Based on these observations, we recommend that field trials of the spoiler baffle design be undertaken. (Spoiler baffles have been installed in the Auckland Region but at the time of writing, monitoring had not been completed.)

Observations made with inanga and smelt also indicate that, as velocities increase, these fish tend to migrate along the edges of the culvert. In such situations, providing resting areas is essential. One product currently on the market, which not only appears to meet this criterion but also considerably reduces barrel velocities, is the Polyflo™ culvert.

In smooth culverts, where baffles must be inserted to reduce barrel velocities and increase water depth, retaining passage along the edges is essential. Thus, where the baffles span the culvert, the ends should be rounded (Figure 20). Another way of improving fish passage is to set a line of baffles along the centre of the culvert, leaving the edges free (Figure 21). As in the traditional offset baffles, the projections need to be angled up stream, not only to maximise energy dissipation, but also to allow small indigenous species to more easily negotiate the ends of the baffles.

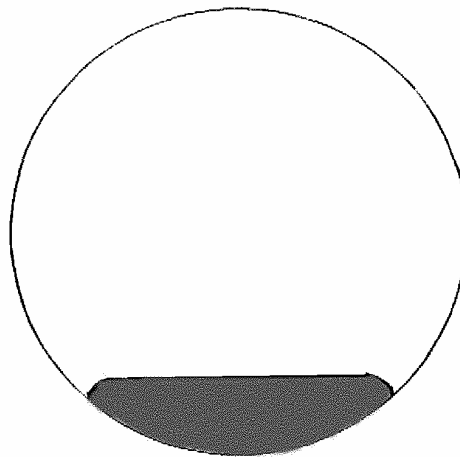

Figure 20. *The rounding of baffle ends is recommended to ease passage of indigenous New Zealand species as they tend to move along the edges of the culvert rather than in mid channel.*

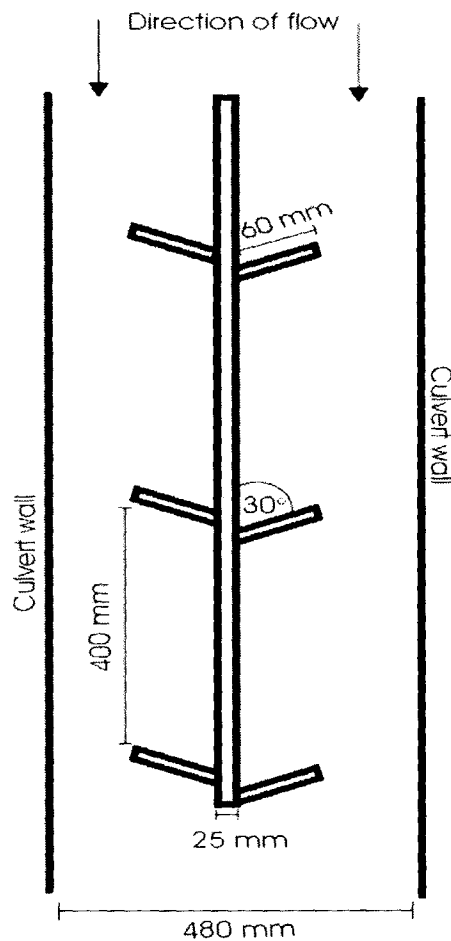

Figure 21. *Plan view of a baffle system installed along the central line of a culvert (diameter = 480 mm) that assisted in the successful passage of inanga. For these trials the baffles were 60 mm high and constructed from timber. Steel or aluminium is recommended for permanent culverts.*

9.3 Other barrel retrofits

9.3.1 Montana bedload collectors

Some culverts in Montana have been retrofitted with detachable "ladders" which collect bedload and create artificially depressed inverts, thereby increasing bed roughness, decreasing velocities and providing resting areas (Figure 22) (Clancy and Reichmuth 1990; Behlke et al. 1991). For ease of transport, the frame is built in sections and bolted together on-site before being bolted to the inlet headwall. The width of the frame is such that it is held 0.3 m above the invert.

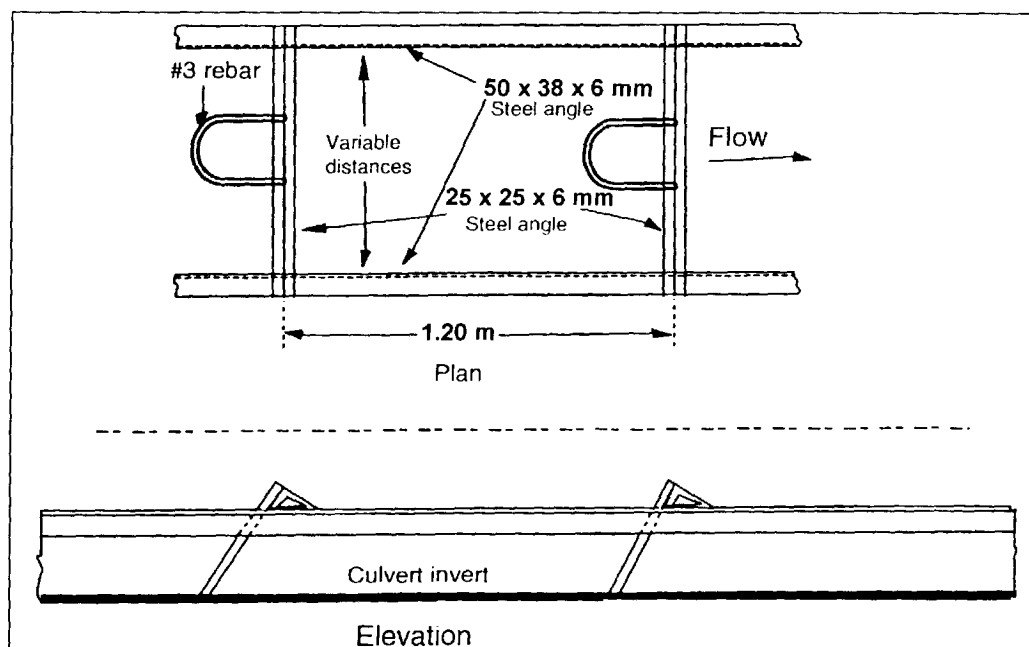

Figure 22. *Montana bedload collector (redrawn with permission. from Clay 1995). These "ladders" trap bedload to create artificially depressed inverts by filling the culvert bottom with debris rather than physically burying it in the streambed.*

Rebar loops welded to the crossbars hold seed boulders, and over time bed material becomes trapped naturally. Such bedload collectors have been used to successfully pass fish through culverts which were previously barriers to migration. The ladders are cheap, easy to install and simply extracted by removing the bolts and pulling them out the downstream end of the culvert.

These ladders need testing in New Zealand conditions as large amounts of debris could become trapped, and thus block the culvert, and/or the ladders could be destroyed by the bedload transport that occurs during floods.

9.3.2 Rebars

Two forms of rebar retrofits have been developed (Behlke et al. 1991):

- i) **Rebar weirs** consist of horizontal rebars simply inserted in holes drilled in the culvert wall 0.3 m above the invert (Figure 23). These devices trap sticks and other debris, forming a more solid weir-like structure. Maintenance is needed to remove large debris which becomes trapped and distorts the flow over the weir. Furthermore, in steep sections (e.g. at the inlet and where settlement occurs) flow can become seriously constricted, leading to very high velocities. The height of the structures commonly installed outside New Zealand is probably too great for our indigenous species. We also suspect

performance would be similar to the weir baffles we tested in the laboratory and will not be very useful for small indigenous fish species.

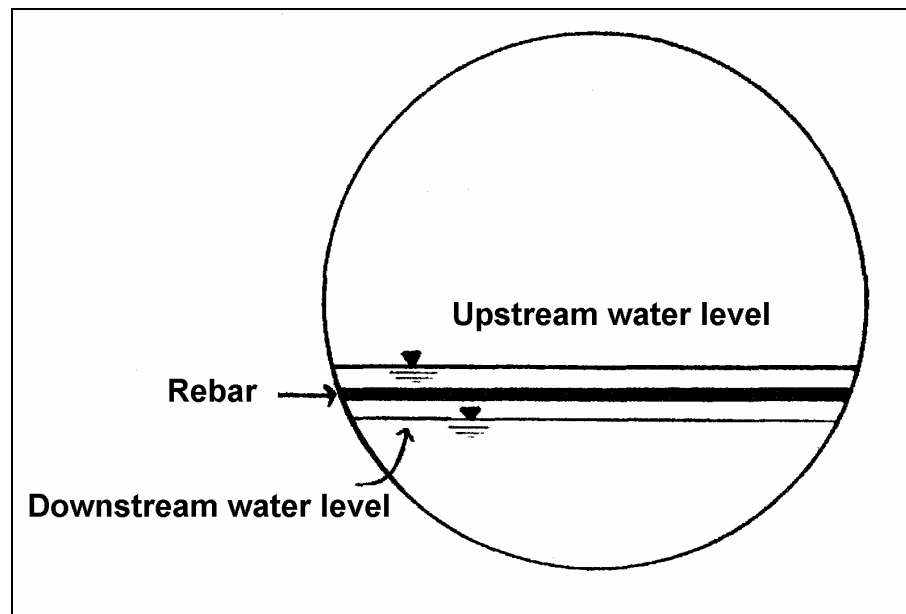

Figure 23. *Rebar weir. Traps debris, forming structures similar to solid weir baffles (redrawn with permission from Behlke et al. 1991).*

- ii) **Rebar and boulder arrangements** consist of diagonal rebars inserted in holes in the culvert wall and angled in alternating upstream and downstream directions, with boulders placed in the V between the wall and the lower end of each rebar (Figure 24). This creates a zig-zag pattern of flow, provides resting areas behind the boulders and is anticipated to trap debris and form diagonal weirs. The rebars must be of large enough diameter to withstand floods, and culverts fitted with this system should have depressed inverts.

Both the rebar weirs and the rebar and boulder arrangements are likely to present serious maintenance problems in New Zealand. Due to the nature of the country and climate, New Zealand rivers possibly carry more sediment and debris than those in North America and the above designs are liable to cause blockage of the culvert during floods.

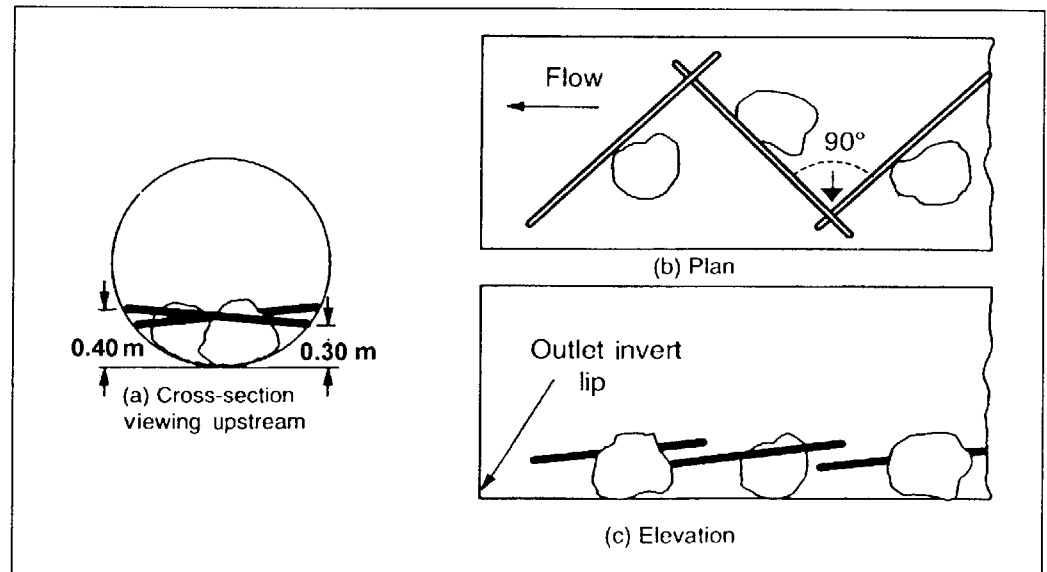

Figure 24. *Alternate diagonal rebars. Trap debris and create resting areas, and a zig-zag flow pattern (redrawn with permission from Clay 1995).*

9.4 Inlet and outlet pools

The provision of both inlet and outlet pools (Figure 1) will serve a variety of purposes for both salmonids and indigenous New Zealand species, and will help in preserving the integrity of the culvert, by providing:

- a resting area prior to ascending the culvert;
- a resting area upon leaving the culvert;
- backwatering of the culvert to decrease velocity and provide sufficient depth in the barrel;
- dissipation of energy from water exiting the culvert to decrease both downstream velocities and the potential for erosion immediately below the outlet;
- elimination of elevated outlets;
- a pool for salmonids to gather speed to jump;

Various configurations of pool dimensions have been proposed. Outlet pool lengths and widths of two times the culvert diameter are advocated by Dane (1978a and 1978b) and Baker and Votapka (1990). By contrast, Metsker (1970) recommends an outlet pool length of up to five channel widths, with a pool-riffle sequence every five to seven channel widths. In New Zealand streams, it is essential when creating such pool-riffle sequences to ensure that the material used will not erode. Embedding large rocks in the substrate in V arrangement, with the point up stream such that pressure is

transferred to the downstream rock and hence to the banks, is an effective way of ensuring the integrity of weirs (Plate 9).

Several tailwater control devices and pools may be necessary to elevate the water level at the outlet. The provision of a 30–60 m series of pools is recommended by Metsker (1970), for resting, cover and protection up stream and down stream of the culvert.

Pool depths of at least 0.6 m below the culvert invert have been recommended for salmonids by both Dane (1978a and 1978b) and Baker and Votapka (1990). Pools of 0.1–0.2 m are likely to be suitable for New Zealand's smaller indigenous fish species. Principles developed by Howie (1968) for designing pool structures have been successfully applied in New Zealand (Cocks 1993). For salmonids, a fall height to pool depth ratio of 1:1.25 is necessary to generate the best conditions to assist with leaping (Dane 1978a and 1978b; Powers and Orsborn 1985). For indigenous species, a low-velocity zone on the edges with depth of around 0.05–0.1 m is essential.

The tailwater control devices used to create these pools may be low sills constructed of mortar or riprap (Plate 10), gabion baskets, or logs. Whatever the material, it is essential that the structure does not in itself impede upstream fish passage. Riprap and boulders have the advantage of blending in with the stream environment, and fish can use its variable roughness to pass over the structure. Where a low sill is provided, it should be constructed so that water flows over the structure, and not through it. The control device should have shallow sloping sides and contain a channel or notch, allowing fish to pass over it during periods of low discharge (Figure 25). This low-flow notch may be placed on alternate sides of successive devices to dissipate the strength of the current (Cocks 1993). Dane (1978a and 1978b) recommended a 0.6 m wide by 0.3 m deep notch for North American fish species. Smaller notches are likely to be suitable for New Zealand's indigenous fish.

Riprap is often used to prevent scouring of the pool by water exiting the culvert, and to provide a transition zone between the tailwater control device and the natural gradient. Knowing the velocity of water exiting the culvert and the size of the bed material, it is possible to determine whether erosion will occur immediately downstream from the culvert and take steps to prevent this. Table 4 gives some indication of the size of material which different water velocities can move. WORKS (1988) provides detailed information for determining the appropriate size of riprap to use for given outlet velocities and channel slopes. Checking the channel and other culverts in the area may also reveal a common erosion problem caused by local sediments or land use changes (Bates 1992).



Plate 9. *V-notch weir constructed from rocks. Note that each rock leans on the one down stream to ensure the stability of the structure. The central rock (submerged) is the lowest so as to create a notch in mid channel.*



Plate 10. *Outlet pools created by a series of small rock weirs. Such pool and weir structures provide resting areas, eliminate elevated outlets through backwatering, and decrease barrel velocities at low flows.*

Continue to next file: culverts04.pdf